

MICRO BLOWERS

TF037F

FEATURES

- Aerodynamic bearings
- Compact / Light weight
- High static pressures
- Low vibration
- Long life due to aerodynamic bearings without heat dependence
- Resin in full compliance with FDA standards



STANDARD SPECIFICATIONS

● Unless otherwise specified, the environmental conditions are 23°C±5°C, normal humidity, and atmospheric pressure range 90 to 106 kPa.

| No. | Item | Part number | TF037F-2000-F | Remarks |
|-----|-------------------------------|-------------|--|--|
| 1 | Operating Voltage Range | | 10~30 V | |
| 2 | Direction of Rotation | | CCW (Counterclockwise viewing from the air vent side) | |
| 3 | Kind of Gas | | Normal Air | Do not use to any corrosive gas. |
| 4 | Type of Motor | | 3 phase 8 pole Brushless (Y Connection) | |
| 5 | Number of Poles | | 8 Poles (4 pole pairs) | |
| 6 | Bearing Type | | Aero Dynamic Bearing | |
| 7 | Recommended Mounting Position | | Axis Vertical (Plate Downward) | Avoid vibration and shock while the product is operating. It may damage product |
| 8 | Maximum Input Coil Current | | 3.0 A Max. | In case, the rotor is lock up, the coil may be destroyed by surge current. The protection circuit to prevent surge current must be installed for safety. |
| 9 | Power Supply Current | | 0.9 A Max. | at 3.0 kPa 100 L/min Temperature: 23±5°C, Humidity: 45~85%RH, Air Pressure: 101.3 kPa |
| 10 | Power Consumption | | 21.6 W Max. | |
| 11 | Minimum Flowrate | | 5 L/min | |
| 12 | Torque Constant | | 0.0025 N·m/A | |

TF037F

MICRO BLOWERS

| No. | Item | Specification | Remarks |
|-----|------------------------------------|---|---|
| 13 | Rotation Speed Range | 6,000~45,000 rpm | Rotation Speed = Hole Sensor Frequency×15 |
| 14 | Acoustic Audible Noise | 65 dB(A) at 3.0 kPa 100 L/min Temperature:23±5°C, Humidity:45~85%RH, Air Pressure:101.3 kPa | Measured 1 m away from the intake vent (Including dark noise as 15 dB) |
| 15 | Coil Resistance | 0.5 Ω | at 20°C (Between 2 phase) |
| 16 | Coil Inductance | 20 μH | at 20°C, 10 kHz (Between 2 phase) |
| 17 | Insulation Class | E grade (JIS C 4003 Cable for Coil) | |
| 18 | Insulation Resistance | 20 MΩ Min. between Coil terminal and Plate at 500 VDC(JIS C 4003) | |
| 19 | Insulation Pressure Resistance | Leak Current: 1 mA Max. | JIS C 4003 At min 600 VAC between coil terminal and plate more than one second |
| 20 | Weight | 72 g (reference value) | |
| 21 | Rotor Inertia | 1.9×10^{-6} kg·m ² (reference value) | |
| 22 | Operating Temperature And Humidity | -10~60°C, 10~95%RH | Condensation may cause damage to product. |
| 23 | Storage Temperature Humidity range | -20~60°C, 10~95%RH | Condensation may cause damage to product. |
| 24 | Operating Ambient Pressure | 770~1,060 hPa | |

OPERATING RANGE IN P-Q & Q-I RATING

- P-Q and Q-I conditions must not exceed the ratings listed below.
- The general purpose driver TF037E-1000-D is setup to the configuration for general use. In using the general purpose driver, the output may not reach the maximum ratings listed below.
- P-Q and Q-I characteristics are for reference purpose only. The driver must be configured properly by measuring the actual condition before use.
 - ※ The characteristics below are measured with our company's driver at axis vertical position.
 - ※ Ambient Temperature : 25°C, Barometric Pressure: 101.3 kPa

Characteristics at 12 V P-Q/Q-I

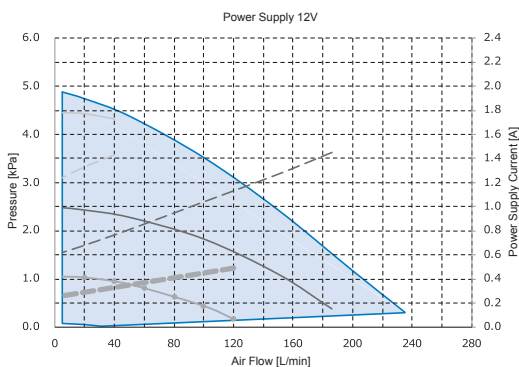

Characteristics at 24 V P-Q/Q-I

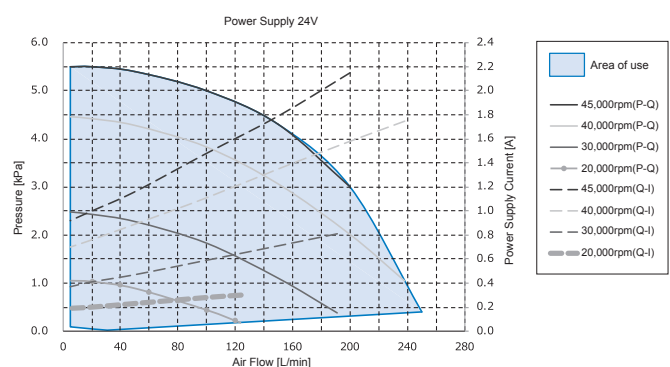

TF037F

MICRO BLOWERS

CONNECTOR

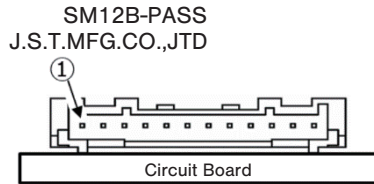

HARNESS SIDE

| | |
|------------------------------|-------------------------------------|
| J.S.T.MFG.CO.,JTD SM12B-PASS | |
| Pressure Welding | 12PAF-6S (Retainer: PAFS-12V-S) |
| Crimping | PAP-12V-S (Contact: SPHD-001T-P0.5) |

- Both pressure welding and crimping are available.
- Recommended size: AWG#22

TERMINAL ARRAY

| Pin No. | Symbol | Content |
|---------|--------|-----------------------|
| ① | Vcc | Power for Hall Sensor |
| ② | H2- | Output of Hall 2 |
| ③ | H2+ | |
| ④ | H3- | Output of Hall 3 |
| ⑤ | H3+ | |
| ⑥ | H1- | Output of Hall 1 |
| ⑦ | H1+ | |
| ⑧ | GND | GND |
| ⑨ | TH | Thermistor |
| ⑩ | V | Coil (V) |
| ⑪ | W | Coil (W) |
| ⑫ | U | Coil (U) |

INTERNAL CIRCUIT / LIMITING RESISTOR

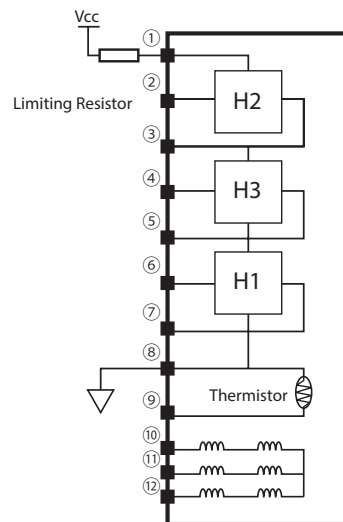

TIMING CHART

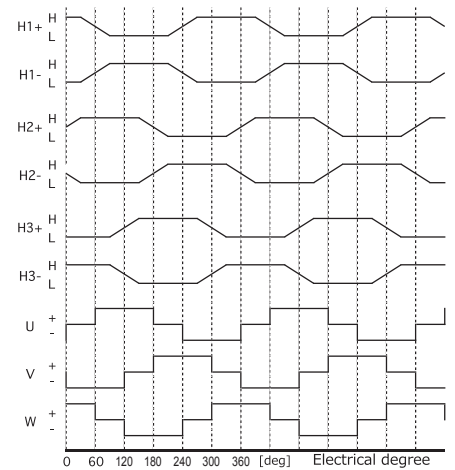

- The current into the hall sensor must be restricted within the rating listed below by using a resistor.

HALL SENSOR CHARACTERISTIC

| | | |
|---------------------|-----------------|---|
| Input Current | 10 mA Max. | At maximum operating load at temperature 60°C |
| Input Resistance | 250~450 Ω | Per one Hall sensor |
| Differential Output | 300 mV p-p Min. | VH = (VH+)-(VH-) at 10 mA in Input current |

• Equivalent of ASAHI KASEI Electronics HW-105A

THERMISTOR CHARACTERISTIC

| | |
|---------------------------|---------------------------------------|
| Reference Resistance 25°C | 10 kΩ |
| Operating Current 25°C | 0.31 mA |
| B Constant [25/85°C] | 4,100 K |
| Maximum Temperature | 86°C (Thermistor Resistance: 0.97 kΩ) |

• Equivalent of TDK NTCG164BH103JT

TF037F MICRO BLOWERS

OUTLINE DIMENSIONS

Unless otherwise specified, tolerance : ± 0.5 (Unit: mm)

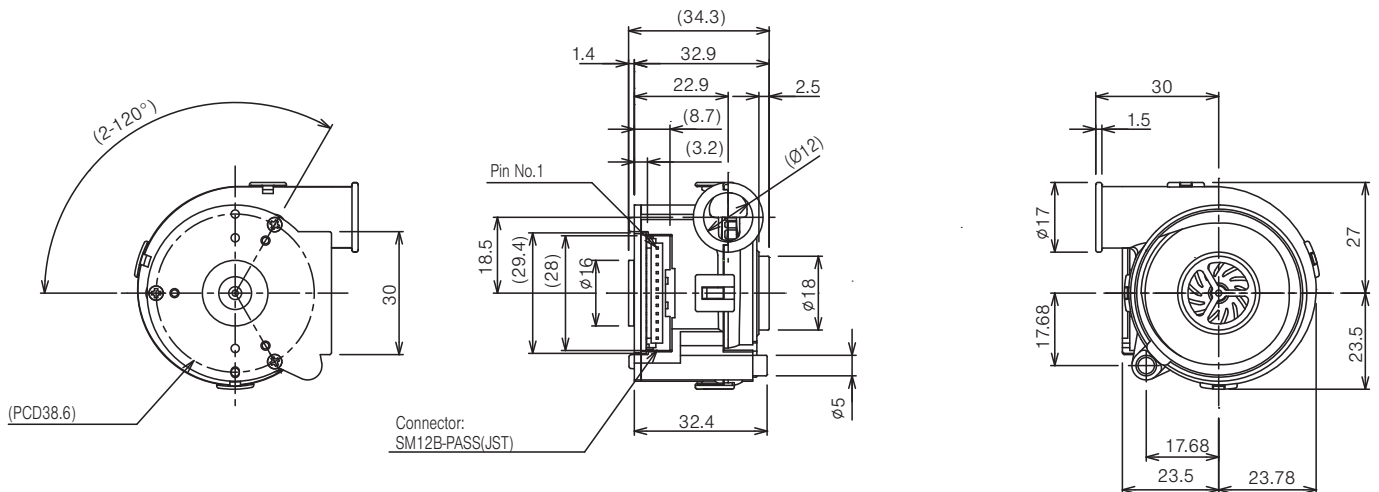

MARKING

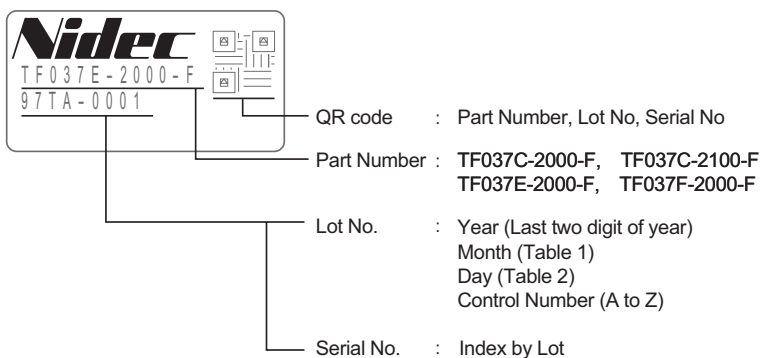

【Table 1】

| | | | | | | | | | | | | |
|-------|---|---|---|---|---|---|---|---|---|----|----|----|
| Month | 1 | 2 | 3 | 4 | 5 | 6 | 7 | 8 | 9 | 10 | 11 | 12 |
| No. | 1 | 2 | 3 | 4 | 5 | 6 | 7 | 8 | 9 | O | N | D |

【Table 2】

| | | | | | | | | | | |
|-----|---|---|---|---|---|---|---|---|---|----|
| Day | 1 | 2 | 3 | 4 | 5 | 6 | 7 | 8 | 9 | 10 |
| No. | 1 | 2 | 3 | 4 | 5 | 6 | 7 | 8 | 9 | A |

| | | | | | | | | | | |
|-----|----|----|----|----|----|----|----|----|----|----|
| Day | 11 | 12 | 13 | 14 | 15 | 16 | 17 | 18 | 19 | 20 |
| No. | B | C | D | E | F | G | H | J | K | L |

| | | | | | | | | | | | |
|-----|----|----|----|----|----|----|----|----|----|----|----|
| Day | 21 | 22 | 23 | 24 | 25 | 26 | 27 | 28 | 29 | 30 | 31 |
| No. | M | N | P | Q | R | T | U | V | W | X | Y |

Micro Blower Kit with driver

For the series, Kits with driver and wire harness for the blower available. They will help customers shorten their evaluation and product development times.

Kit Part Number : TF037F-2000-P

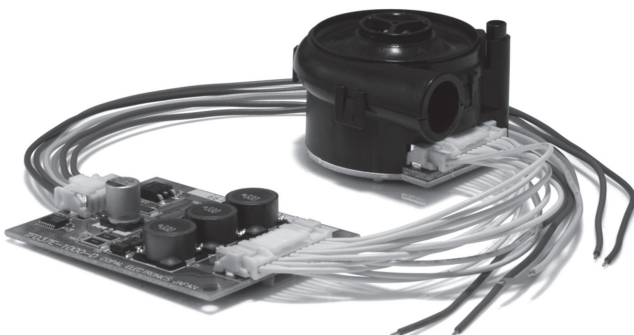

| List of the kit | |
|-----------------|---|
| 1 | Micro Blower (TF037F-2000-F) |
| 2 | Driver (TF037 series common) |
| 3 | Wire Harness for Driver-Blower connection) |
| 4 | Wire Harness (for Driver-Power connection) |

The Drivers are sold separately as an optional item.