

Multi-turn Dial

# Dial H-46



- Multi-turn analog dial.
- Use with HP-16 and HP-18 10-turn wire wound potentiometer

**【Material】**

- Housing : Zinc, Aluminum, Copper alloy, POM

**Dimension [mm]**

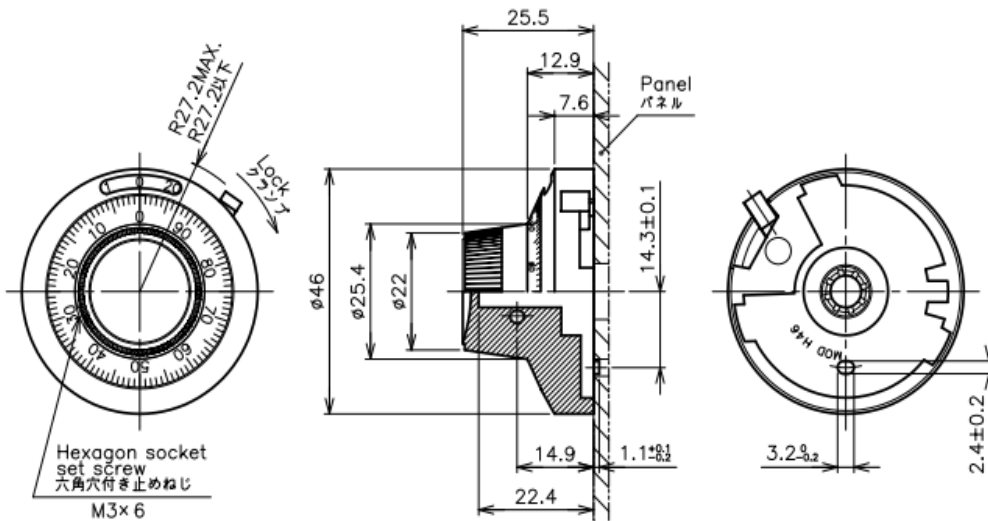

**Mounting [mm]**

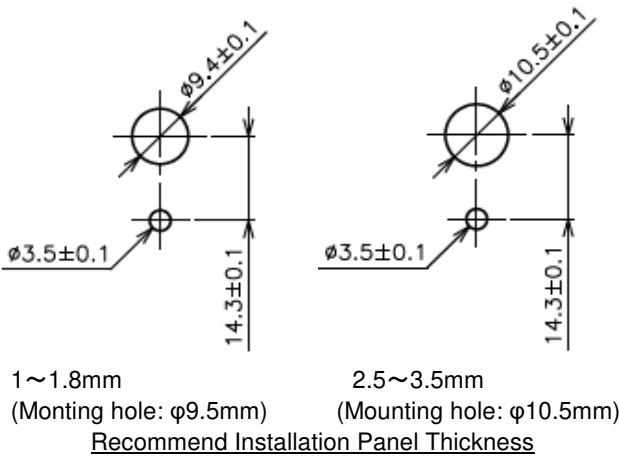

**Note:**

If Panel thickness is  $1.8 < 2.5\text{mm}$ , please use spacers which are inner diameter 10.5mm to become 2.5~3.5mm thickness.

**Using the Antirotation Device**

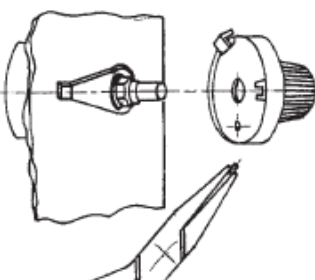

1. Remove antirotation lug from dial by using pliers.
2. Mount potentiometer in panel with antirotation device nut (supplied with dial) and lockwasher (supplied with potentiometer).
3. Turn potentiometer shaft counterclockwise to obtain minimum resistance or voltage ratio. This is not necessarily identical with the mechanical stop.
4. Loosen set screws in knob of dial. Set dial to "0.0" reading.
5. While holding outer ring of dial, position unit lightly against panel. Tighten knob set screws to potentiometer shaft.

**【Specifications】**

Number Of Turns	20	Turns
Minor Scale Division	1/1000	
Mass	73 Approx.	g
Applicable Pot.	HP-18	
Applicable Plate Thinckness	Monting hole: $\phi 9.5$ : 1~1.8 Mounting hole: $\phi 10.5$ : 2.5~3.5	mm

**■Supplied Accessories**

Antirotation device nut : 1pc  
Hexagonal wrench for set screw : 1pc

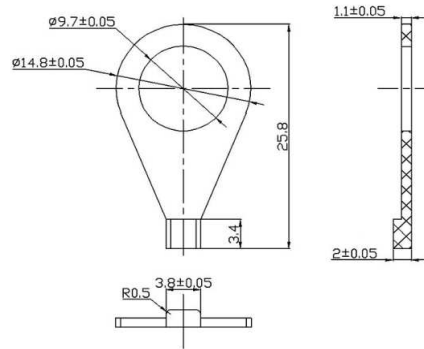
**■Handling Instruction**

This dial is designed for being mounted on potentiometer only and then being rotated by hand.  
Please do not rotate dial at high speed by using motors.