

# WR Series/WR-7UHAx



WR-7UHA series is pendulum type single axis inclinometer, designed for measurement of wide tilt angle range from 90° up to 360°, featuring long useful life and stable output signal due to contactless design. The die cast aluminum housing is sealed for operation in hostile environments. This model is especially suited for boom angle control of construction machinery.

### 【Specifications】

	WR-7UHA	WR-7UHA360
Electrical Tilt Angle	120°	360°
Output Ratio	5 ~ 95 %Vin	
Index Point	50 ± 1 %Vin	
Absolute Linearity	±0.8 %FS	±0.4 %FS
Tilt Sensitivity	±0.5 %FS	±0.3 %FS
Input Voltage	DC 5±0.5 V	
Load Resistance	10 kohm Min.	
Current Consumption	10mA Max.	
Temp. Characteristics		
-30~80°C(Reference Temp.25°C)	±0.4 %FS	±0.3 %FS
Mechanical Tilt Angle	360° endless	
Response Time (Step Response)	Approx. 0.3 second	
Mass	Approx. 260 g	
Category Temperature Range	-30~+80°C	
Storage Temperature Range	-40 ~ 80 °C	
Vibration	50m/s <sup>2</sup> 5~500Hz (6 min.) 3 axis 2 hours	
Shock	500m/s <sup>2</sup> 11ms 6 directions 3 times	
EMS	100 V/m、200M~1GHz	
ESD	±15 kV	
IP Level	IP 64	

■Option: Available Electrical Tilt Angle 90°~360°

### 【Dimension (mm)】

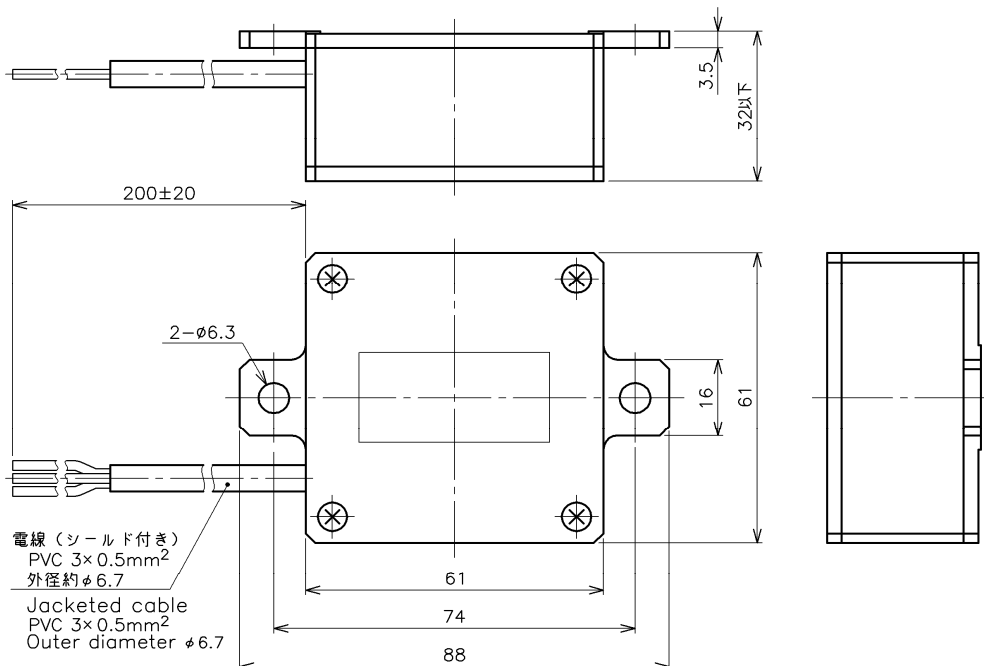

**[Output Characteristics]**  
WR-7UHA

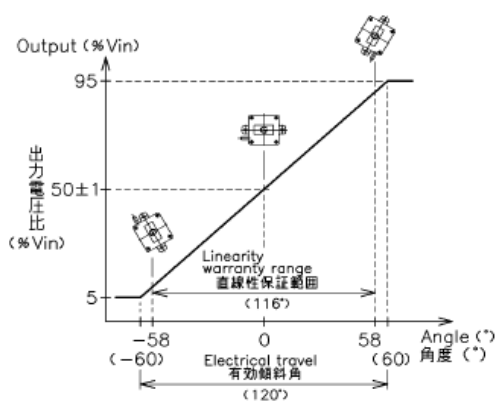

**[Schematic]**

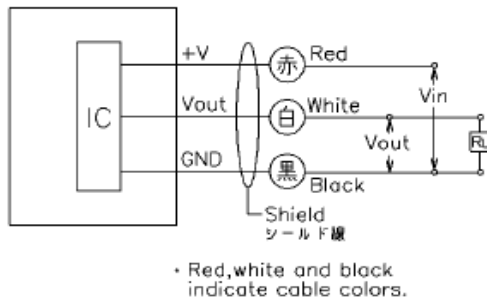

WR-7UHA360

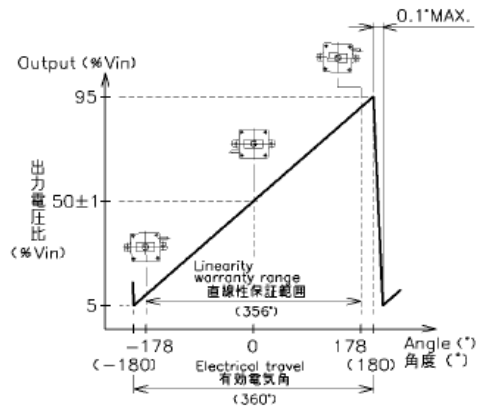

**[Mounting]**

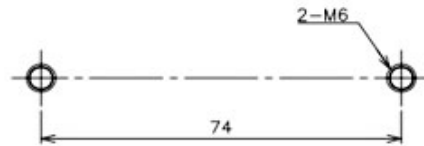

**Performance**

**Wide Tilt Range**

Available Electrical Tilt Angle 90° ~360°

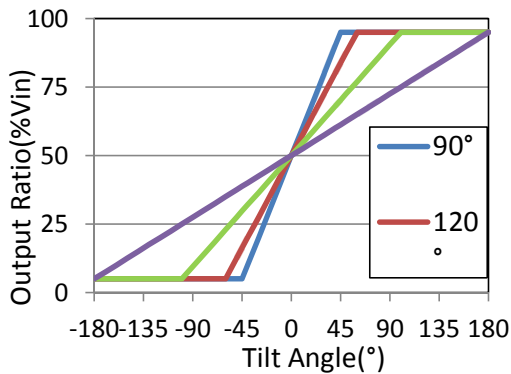

**High Accuracy**

Absolute Linearity  $\pm 0.8\%$ FS(FS=120°)

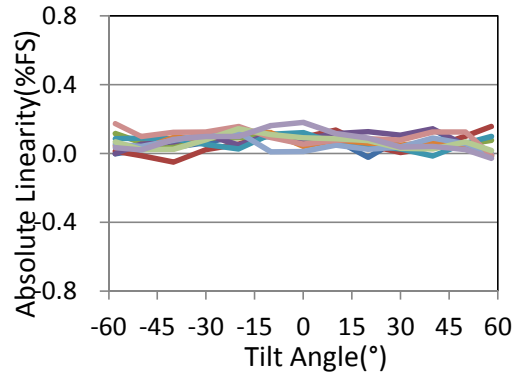

**High Reliability**

Temp. Characteristics  $\pm 0.4\%$ FS(FS=120°)  
(Range : -30~80°C)

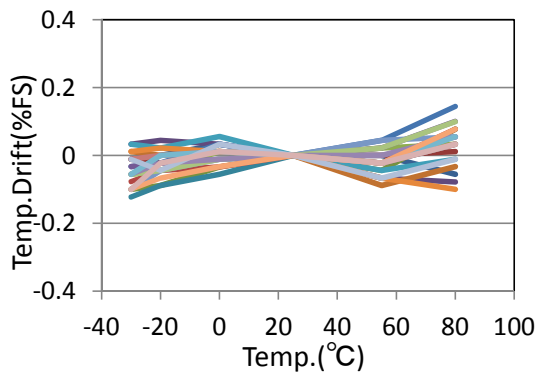

**EMS 100V/m**

Not affected to output voltage.

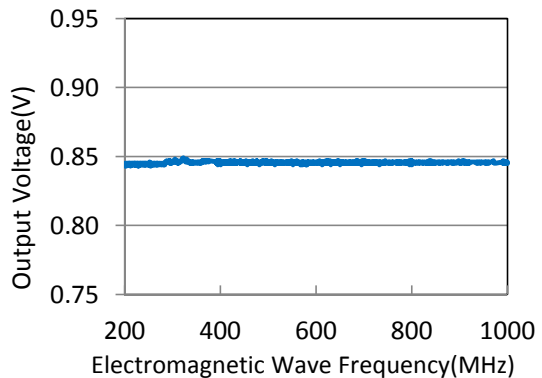

### ■ Handling Instruction

- Hall-IC sensor is impossible to measure resistance value as a variable resistor.
- This product may be influenced from external magnetic field.
- Use this sensor in the place where is protected from ESD.