

# DC BRUSHLESS AXIAL FAN

# R40W12BGNL9-07

The UltraFlo series is a fan lineup that achieves high airflow, low power consumption, and long lifespan, boasting the world's top share in the communication IT field. The highly reliable fan motor is widely used in various applications. In addition to its expertise in precision small motors, it combines wind tunnel design and circuit design with safety mechanisms, offering a wide range of sizes from 1U to 4U. The lineup also includes dual-reverse fans to meet the high static pressure area required to send air into high-density enclosures, providing an effective means to increase redundancy.



## CHARACTERISTIC CURVES

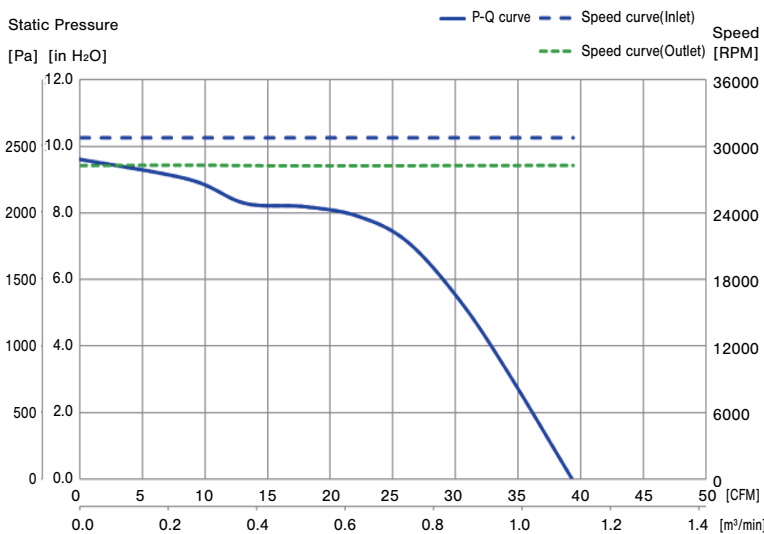

## FEATURES

- 40 x 40 mm 12 VDC Brushless Fan
- High Airflow (39.2 CFM @ 1.11 m<sup>3</sup>/min)
- Low Current Consumption 3.52 A (Nominal) 3.87 A (Peak)
- Long Lifespan 70,000 hours @ 40°C & 65 % R.H. (L10 Expectancy)
- Ball Bearings
- Counter Rotor Fan
- PWM Speed Control With Tach Output

## 1. MECHANICAL SPECIFICATIONS

1-1	External dimensions	Refer to outline dimensions
1-2	Housing material	PPS (UL94 V-0)
	Impeller material	PPS (UL94 V-0)
1-3	Bearing	Ball bearings
1-4	Mass	About 105 g
1-5	Life expectancy L10	70,000 hours 1) At 40°C (65 % R.H.), continuous operation at rated voltage. 2) Life is defined when the motor speed decreases more than 30% against its initial speed.

# R40W12BGNL9-07

## DC BRUSHLESS AXIAL FAN

### 2. ELECTRICAL SPECIFICATIONS

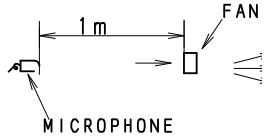
No	Item	Part number	R40W12BGNL9-07	Remarks
2-1	Rated voltage		12 VDC	
2-2	Operating range		10.8~13.2 V	(Note 5)
2-3	Current consumption		Max. 3.87 A 3.52 A (Nominal)	In free air at rated voltage (Note 2)(Note 6)
2-4	Power consumption		Max. 46.4 W 42.2 W (Nominal)	In free air at rated voltage
2-5	Rated speed		Min. 27900 min <sup>-1</sup> 31000 min <sup>-1</sup> (Nominal) Max. 34100 min <sup>-1</sup>	In free air at rated voltage Inlet side (Note 2)
			Min. 25200 min <sup>-1</sup> 28000 min <sup>-1</sup> (Nominal) Max. 30800 min <sup>-1</sup>	In free air at rated voltage Outlet side (Note 2)
2-6	Maximum air flow		Min. 0.94 m <sup>3</sup> /min (33.5 CFM) 1.11 m <sup>3</sup> /min (39.2 CFM)	At rated voltage At zero static pressure (Note 2)
2-7	Maximum static pressure		Min. 1823 Pa (7.32 inch-H <sub>2</sub> O) 2369 Pa (9.51 inch-H <sub>2</sub> O)	At rated voltage At zero air flow (Note 2)
2-8	Acoustic noise		Max. 78.0 dB (A) 74.0 dB (A) (Nominal)	In free air at rated voltage (A scale, slow) 
2-9	Operating temperature		-10°C~70°C (Normal humidity)	
2-10	Storage temperature		-40°C~75°C (Normal humidity)	Standards for Items 2-3~2-8 should be met when measured after having sat for 24 hours at room temperature for fans subjected to specified temperature range for 100 hours.
2-11	Direction of rotation		Inlet : CW Outlet : CCW From exhaust side	
2-12	Direction of air flow		Label side discharge	
2-13	Insulation resistance		Min. 10 MΩ	At 500 VDC between frame and lead wires
2-14	Dielectric strength		Must withstand 500 VAC 1min	Max. 1mA between frame and lead wires (Usually inspect at 600 VAC, 1 sec, 1 mA)
2-15	Protection		Current limit protection	(Note 3)
			Reverse polarity protection	(Note 4)
			Hot swap	

- Note 1: The standards should be the specified value at normal temperature (23°C) and normal humidity (60~65%) unless otherwise notice. As to the value of item 2-3~2-8, it should be measured after 10 minutes operation.
- Note 2: Control signal(Blue and green lead wire) should be applied 2.0~4.0 V, or should be open.
- Note 3: In the case that power is turned on during fan rotor is locked, the fan shall attempt to restart at a typical repetition rate(Temperature rise will be prevented). The fan will automatically restart when the locked rotor condition is released.
- Note 4: Power supply voltage must not be applied between signal output line and any other line directly. Reverse polarity protection is effective to just switch the positive and negative power line.
- Note 5: 10.8 V~13.2 V operating voltage is for continuous DC voltage. Power supply voltage ripple 5% maximum.
- Note 6: The max value of current consumption does not represent the peak value.

# R40W12BGNL9-07

## DC BRUSHLESS AXIAL FAN

### 3. PROVISION OF REVOLUTION SIGNAL

#### 3-1 OUTPUT OF REVOLUTION SIGNAL

- Output type: open collector type
- Electrical specification

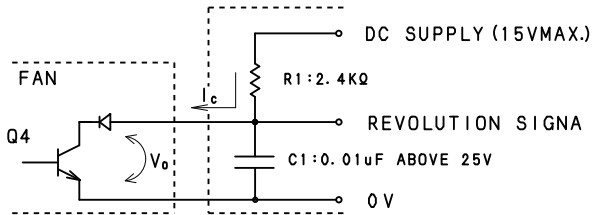

Remark: As for measuring  $V_{OL}$ , it is necessary to put or low pass filter which is constructed of R1 and C1. The time constant of  $R1 \times C1$  is to be more than 24us such as  $R1=2.4\text{ k}\Omega$   $C1=0.01\text{ }\mu\text{F}$ .

- Absolute maximum specification
  - Collector current  $I_C=10\text{ mA Max.}$
  - Release Voltage  $V_{OH} = 15\text{ V Max.}$
- Electrical characteristics
  - Saturation Voltage  $V_{OL} = 0.8\text{ V Max.}$
  - At  $I_C=5\text{ mA}$

#### ● Output waveform

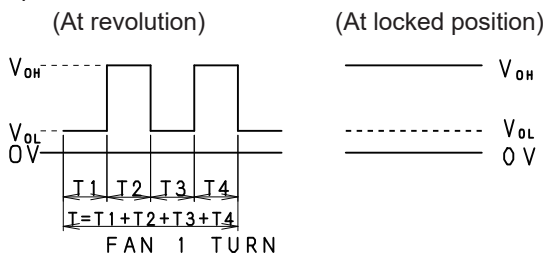

Remark: At locked position, output becomes  $V_{OH}$  OR  $V_{OL}$ .  
 $T=T_1+T_2+T_3+T_4=60/N$  (Sec)  
 $N$ : Fan Speed ( $\text{min}^{-1}$ )  
 $DUTY = T_1 / (T_1+T_2) = 50 \pm 10\%$

#### 3-2 ⚠ CAUTION

Please be careful that revolution signal lead wire (Yellow & white lead wire) shall not have any voltage directly applied. (It should damage inner circuit.)

### 4. PWM CONTROL

#### 4-1 TYPE

The method of active/inactive drive mosfet for speed control.

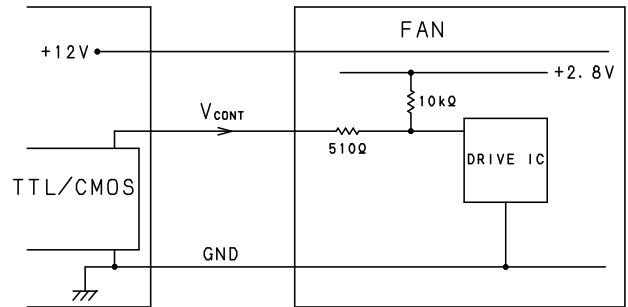

$V_{CONT}$  is above 2.0 V ... Fan should run full speed.  
 $V_{CONT}$  is below 0.8 V ... Fan should low speed.

The wire of  $V_{CONT}$  is open ... Fan should run full speed.  
 Control signal should accept PWM control,  
 PWM frequency is from 20 kHz to 30 kHz.

#### 4-2 PWM CONTROL SIGNAL

Signal voltage range: 0~4.0 VDC

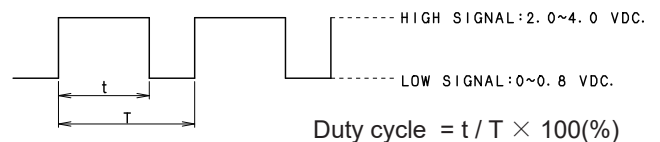

The frequency for control signal of the fan shall be able to accept at 20 kHz-32 kHz.  
 PWM signal with 3.3 VDC TTL/COMS(OD/OC) level. The preferred operating point for the fan is 25 kHz, and duty cycle from 0% to 100%.  
 If the PWM control wire connect to ground, the rotor will spin at minimum speed.  
 If the PWM control wire open, the rotor will spin at maximum speed.

# R40W12BGNL9-07

## DC BRUSHLESS AXIAL FAN

### 4-3 SPEED VS PWM CONTROL SIGNAL, AT RATED VOLTAGE

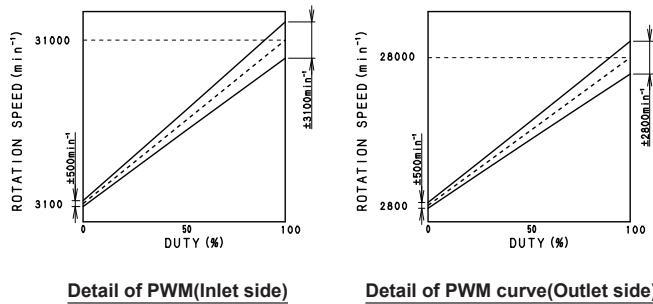

Duty cycle (Positive) (%)	Speed (min <sup>-1</sup> )	
	Inlet side	Outlet side
0	3100±500	2800±500
50	17050±1705	15570±1557
100	31000±3100	28000±2800

Note: The standards should be the specified value at normal temperature (21~25°C) and normal humidity (60~65%), and free air unless otherwise notice.

## 5. SPECIAL TEST

### 5-1 VIBRATION TEST

Standards for items 2-3~2-8 and 6-2 should be met after 30 minutes 0.2mm amplitude, 55 Hz vibration in each direction: up-down, right-left, forward-back, in non-operating condition.

### 5-2 SHOCK TEST

Standards for items 2-3~2-8 and 6-2 should be met if the fans fall naturally from a height of 30cm in the packing box for each direction.

\*Dimensions of Packing Box (W x D x H) :

360 x 540 x 220 (mm)

## 6. OTHERS

### 6-1 CONNECTION

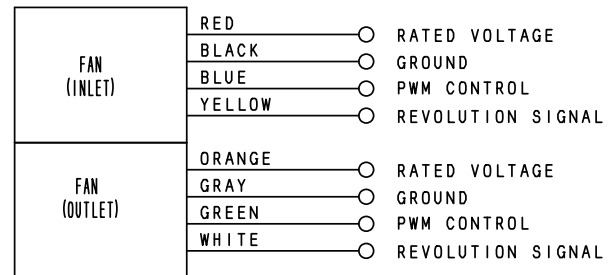

### 6-2 LOCKED ROTOR

No damage shall be found for continuous 1 hour at locked rotor.

### 6-3 ⚠ CAUTIONS IN INSTALLATION OF FAN MOTORS

Please consider system layout not to place any obstacles within 3mm from the fan housing edge of inlet side (Impeller side).

In case of screwing the fan housing, flatness of installation surface should be max. 0.1, otherwise the housing may transform and interfere with the impeller.

The fan should not get any impact or vibration during rotation. When vibration or impact is applied to the fan during rotation, the fan may break by interfering with obstacle in the system.

Please fix the fan in the system so that it will not rattle. Vibration of the fan may cause contact between the fan and the system, which will generate noise.

Please do not place any obstacle near outlet and inlet side of the fan.

Placing obstacles near the fan may deteriorate air flow. It may cause cooling performance reduction as well as fan motor life deterioration due to heavy load on the bearings.

This model is designed to be installed as the screw in flange one side(Refer to figure((a)). In case of installations as the screw through both flanges (Refer to figure ((b)). It may cause damages on the housing and/or interference between the impeller and the housing because of the housing deform.

For any usage that does not meet above conditions, please evaluate at user's side or consult with us.

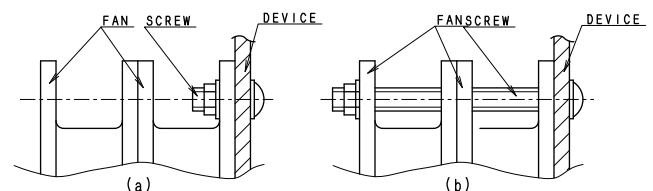

# R40W12BGNL9-07

## DC BRUSHLESS AXIAL FAN

---

---

---

---

---

---

---

---

### 6-4 ⚠ USAGE OF FAN MOTOR

Please do not put resistors or other electronic components on the extension of the fan motor lead wires for the purpose of fan motor speed reduction.

It may make the voltage to the fan fluctuate and become lower than lower limit of operating voltage range.

In this case, there may be such failures like no start or unstable rotation of fan motor.

### 6-5 ⚠ EARTH · ELECTROSTATIC PROTECTION

Electrification and leakage can cause motor circuit or semiconductor failure.

Proper grounding is required for soldering iron and conveyer belt during motor terminal or lead wire soldering to mechanism or set. ( $\pm 200$  V or less)

## 7. SPECIAL ITEMS

### 7-1 WARRANTY

Our warranty is limited to the replacement of failed fan at free of charge, if and only if the failure is found within two years after it was shipped out from our production facility and if the cause of the failure is proven to be attributable to the supplier.

Our liability does not extend to the consequential damages caused by the failed fan.

### 7-2 NOTE

Please consider having an independent protection system in the customer's instruments in the event that the fan should stop operating.

### 7-3 POWER SOURCE

Brushless DC fans are designed to be used at DC power source with bypass capacitor. We would recommend you to use DC power source which is filtered ripple and noise.

- Fans are designed to perform as expected when stable voltage is supplied.
- Fluctuation of the voltage between Vcc(+) and GND while the fan is powered must be within the specified operating voltage range.
- Fluctuation cycle of the voltage between Vcc(+) and GND while the fan is powered must be longer than the fan's rotation cycle.
- GND of the fan must be kept below the voltage of its Vcc(+) when the voltage is switched ON/OFF or the fan is not running.
- Devices that use the fans are supposed to be designed so that the voltage applied on the revolution signal is not affected by power ON/OFF.

### 7-4 ENVIRONMENT-RELATED SUBSTANCES

Based on RoHS3, cadmium, lead, mercury and compound of these substances and hexavalent chromium compound, Polybromo bi-phenyl(PBB) and polybromo di-phenyl ether(PBDE) are not included in this product.

# R40W12BGNL9-07

## DC BRUSHLESS AXIAL FAN

### OUTLINE DIMENSIONS

(Unit:mm)

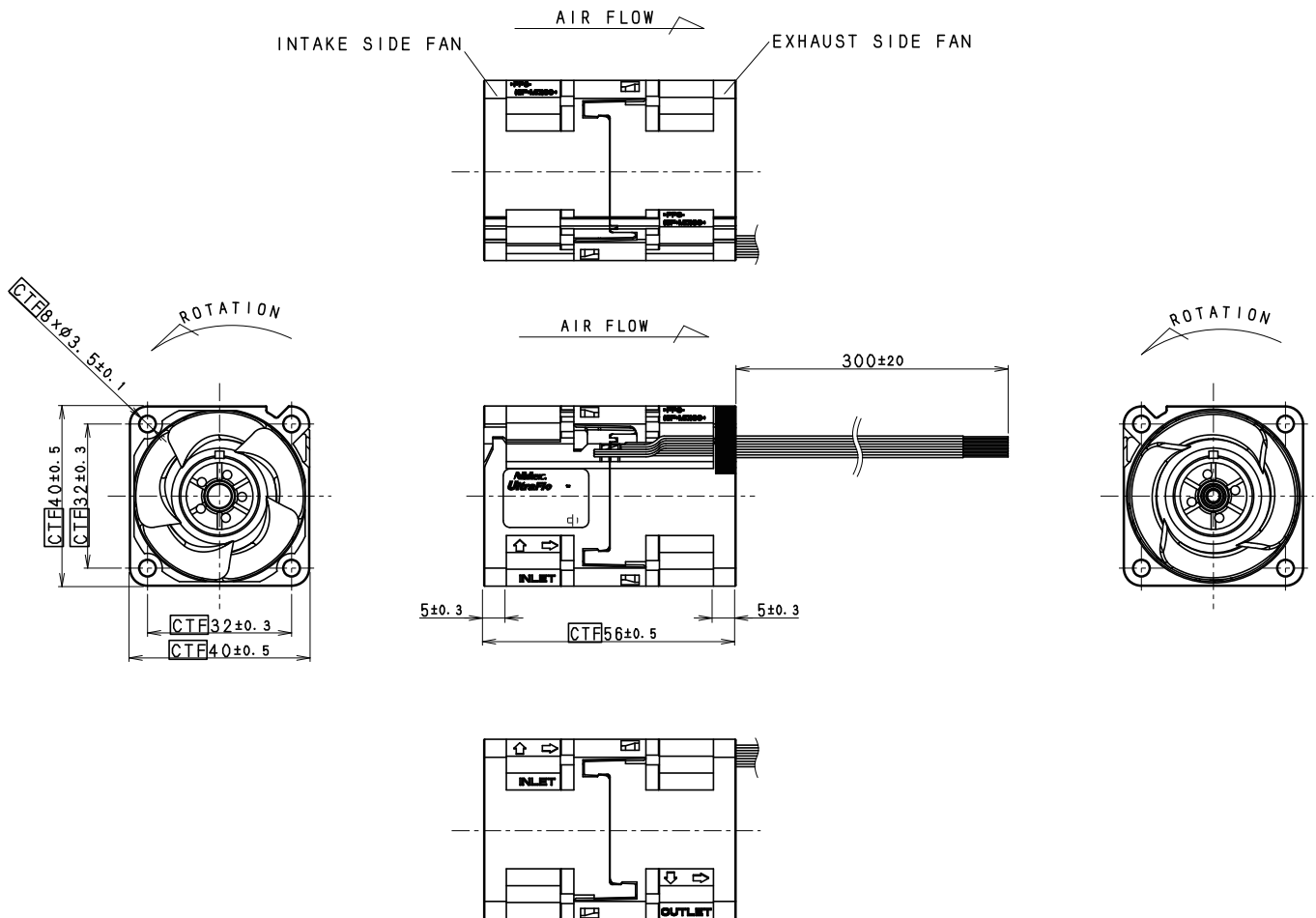

Color	Lead wire	Connection	
Red	UL10368, AWG 24	Inlet	+V
Black	UL10368, AWG 24	Inlet	GND
Blue	UL10368, AWG 26	Inlet	PWM
Yellow	UL10368, AWG 26	Inlet	FG
Orange	UL10368, AWG 24	Outlet	+V
Gray	UL10368, AWG 24	Outlet	GND
Green	UL10368, AWG 26	Outlet	PWM
White	UL10368, AWG 26	Outlet	FG